

# MD19

## INTEGRATED METEOROLOGICAL REPEATER

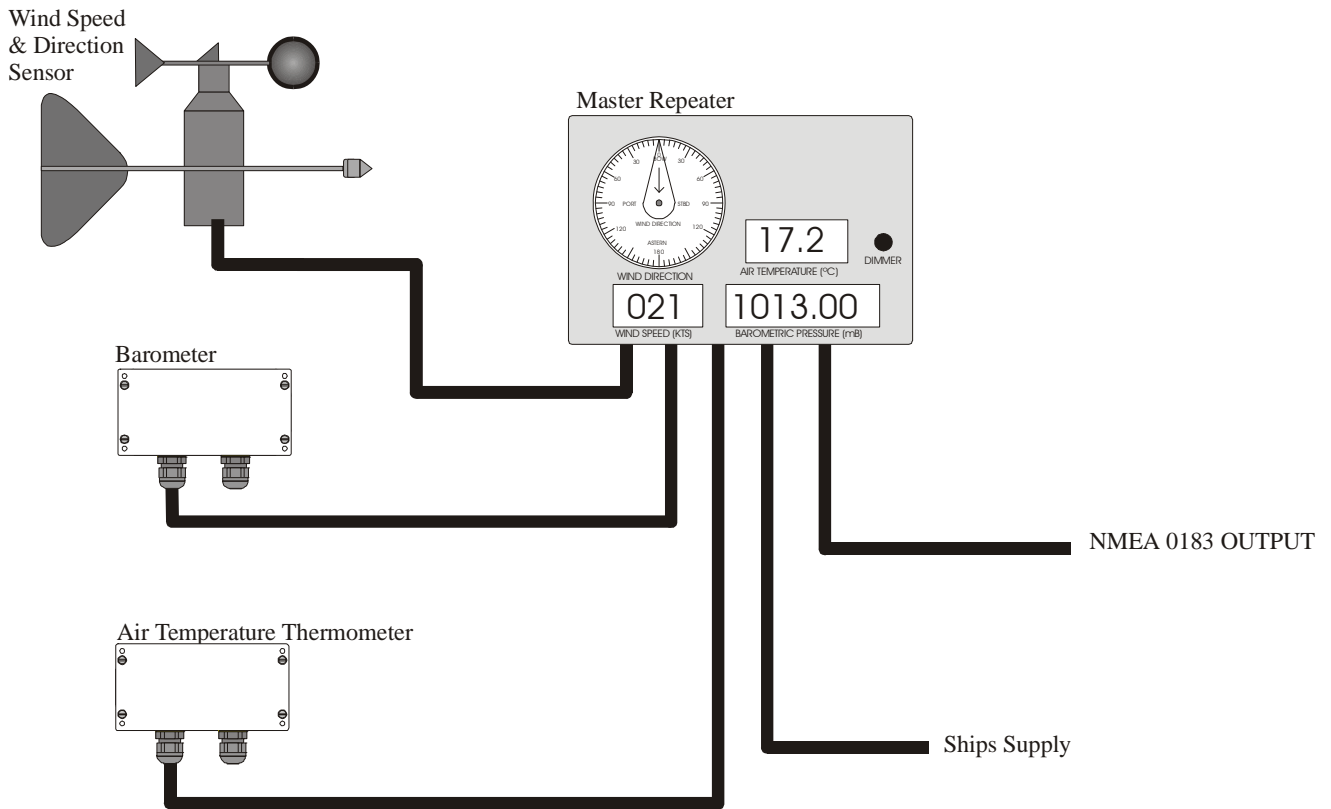

### System application

- Introduction**

The Marine Data Integrated meteorological repeater is a large visible display station that shows wind speed and direction, temperature and atmospheric pressure. It has been designed to integrate into Marine Data manufactured sensors and directly power them as shown in the system diagram above. This has the advantage of cutting down system wiring. In addition it provides three separate channels of wind speed and direction, temperature and pressure digital RS422 outputs which may be integrated into other Marine Data made peripherals or the ships system.

- Controls and indicators.**

The MD19 has only one user control located on its face. This is a single push button that operates the lighting of the repeater. Hold this down until the desired lighting level is reached, then release.

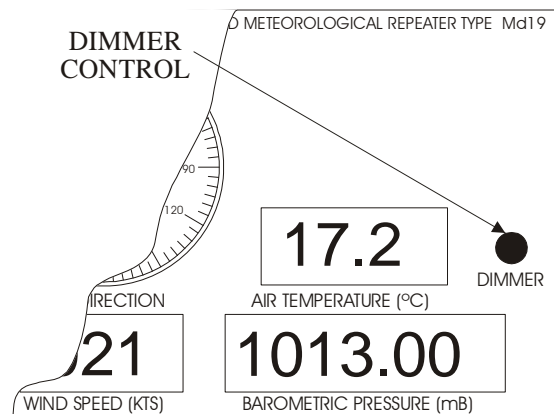

● **Installation.**

Tools required : basic hand tools; D.V.M; megger

Step	Description	Remarks
1	Inspect the packing for contents.	Note any damage or exclusions.
2	Inspect the mounting position for suitable clearance and cable access.	Bulkhead /panel mounting option. (see specification for detail.)
3	Locate signal and power connections	The MD19 is designed to run off a voltage between 100V and 230V 50Hz. It provides a 12V dc supply to the MD14 and 24V supplies to the MD20 and MD23. It requires digital input from the sensors. Isolation and earthing requirements should comply with Lloyd's rules and regs. VI para 1.13.2
4	Mechanically install the repeater	
5	Identify ships wire functions	
6	Wire as indicated below and commission	

## MD19 WIRING INFORMATION

Plug Terminal	Function	Core colour to be filled out by Installer
INPUT1 PIN 1	24V DC	
INPUT1 PIN 6	0V DC	
INPUT1 PIN 2	TDA WIND	
INPUT1 PIN 7	TDB WIND	
INPUT1 PIN 3	TDA TEMP	
INPUT1 PIN 8	TDB TEMP	
INPUT1 PIN 4	TDA PRESSURE	
INPUT1 PIN 9	TDA PRESSURE	
INPUT1 PIN 5	CHASSIS	

Plug Terminal	Function	Core colour to be filled out by Installer
INPUT2 PIN 1	24V DC	
INPUT2 PIN 6	0V DC	
INPUT2 PIN 2	TDA WIND	
INPUT2 PIN 7	TDB WIND	
INPUT2 PIN 3	TDA TEMP	
INPUT2 PIN 8	TDB TEMP	
INPUT2 PIN 4	TDA PRESSURE	
INPUT2 PIN 9	TDA PRESSURE	
INPUT2 PIN 5	CHASSIS	

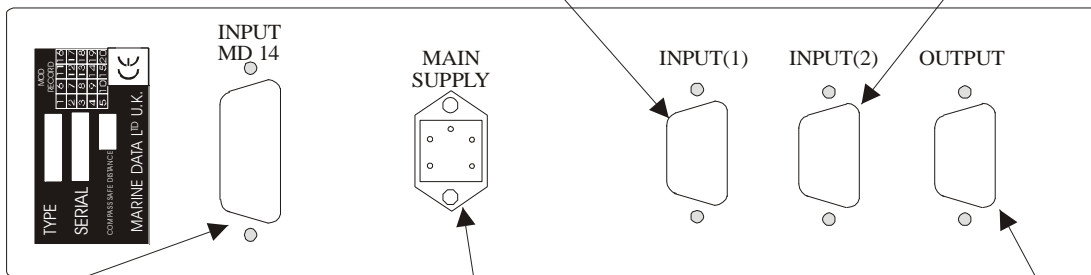

Plug Terminal	Function	Core colour to be filled out by Installer
MAIN PIN 1	LIVE	
MAIN PIN 3	NETURAL	
MAIN PIN 5	EARTH	

Plug Terminal	Function	Core colour to be filled out by Installer
OUTPUT PIN 1	24V DC	
OUTPUT PIN 6	0V DC	
OUTPUT PIN 2	TDA WIND	
OUTPUT PIN 7	TDB WIND	
OUTPUT PIN 3	TDA TEMP	
OUTPUT PIN 8	TDB TEMP	
OUTPUT PIN 4	TDA PRESSURE	
OUTPUT PIN 9	TDA PRESSURE	
OUTPUT PIN 5	CHASSIS	

Plug Terminal	Function	Core colour to be filled out by Installer
14 PIN 1	+12V DC	
14 PIN 9	0V DC	
14 PIN 3	TDA	
14 PIN 11	TDB	
14 PIN 15	SCREEN	

- **System Commissioning**

STEP	DESCRIPTION	REMARKS
1	Ensure that installation is satisfactory	
2	Switch supply and power	
3	The MD19 will provide power and start to receive digital information from it's sensors.	
4	Commissioning is complete	

- **Maintenance and fault finding.**

The MD19 is composed of a sealed unit. If trouble is encountered make the following preliminary checks. If problems persist further contact your supplier in the first instance or us direct so assistance may be given

Symptom	Probable fault	Remedy
The MD19 does not power up and zero correctly on start up.	No mains Power / fuse blown	Check incoming power supply.
The wind information is not present.	Check power to the wind sensor is present.	The 12Vdc power comes from the MD19
	Check TDA and TDB polarity Data to the receiver device is not present.	The digital signal has been swapped TDA and TDB may require reversing.
The Temperature information is not present	Check power to the temperature sensor is present.	The 24Vdc power comes from the MD19.
	Check TDA and TDB polarity Data to the receiver device is not present.	The digital signal has been swapped TDA and TDB may require reversing.
The atmospheric pressure is not present.	Check power to the barometer sensor is present.	The 24Vdc power comes from the MD19
	Check TDA and TDB polarity Data to the receiver device is not present.	The digital signal has been swapped TDA and TDB may require reversing.

- **Available Finished Items and Spare Parts**

In the event that spare parts are needed please contact your dealer or MDL direct.

**SPECIFICATION FOR MD19  
INTEGRATED METEOROLOGICAL REPEATER**

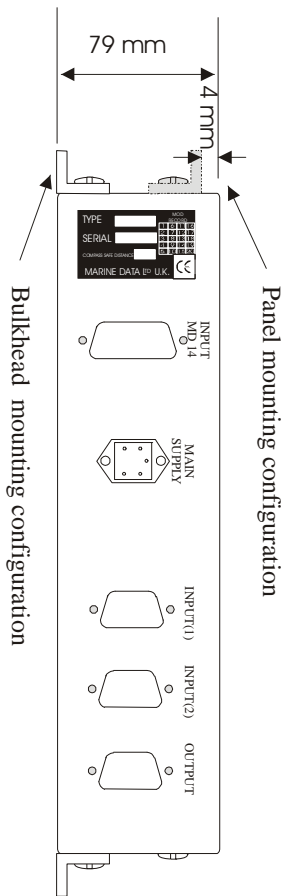
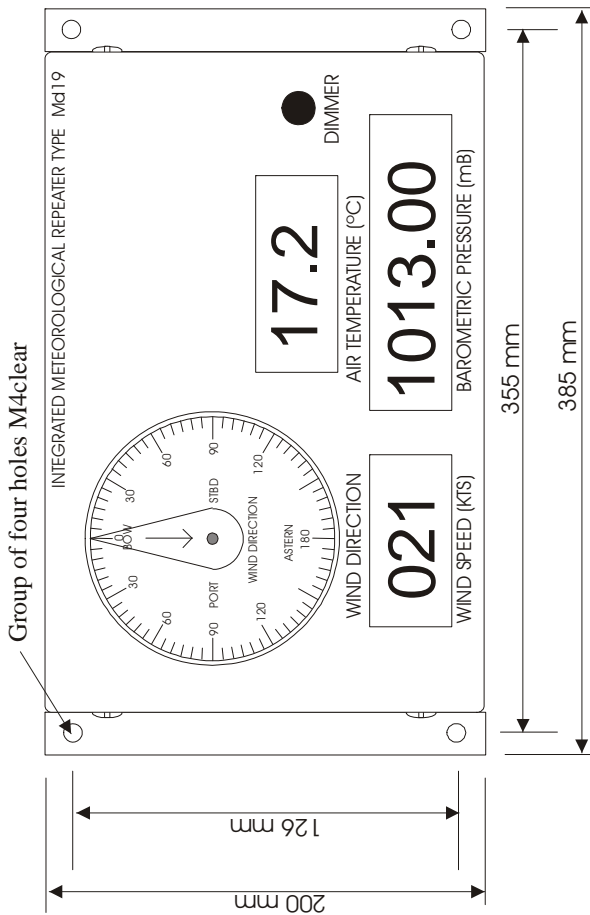

**Physical**

- Weight 4Kg
- Mounting Panel or Trunnion
- Finish Light weatherwork grey BS3816-676
- Connections
  - 1 x 6 way screened cable (15 way D-type fitted ) to MD14 (RS422 \$IIMWV,XXX.X,R,XX.X,N,A<CR><LF> 2x 6way screened cable (9 way D-type male) for Barometer & thermometer input (RS422 \$IIMTA,XXX.X,C<CR><LF> \$IIMB,,,X.XXXXX,B<CR><LF>) 1x 6 way output screened cable (9 way D-type female) output to peripherals
- Construction Aluminium Enclosure

**Electrical**

- Power Supply 110V -220V 50/60Hz main supply

**Operational**

- Performance
  - displays Wind speed (+/-1Knot)
  - Wind direction (+/- 2 degrees)
  - Air temperature (+/- 1°C)
  - Atmospheric pressure (+/- 2 mb)

**Environmental**

- Rating IP54 (IP65 when specially sealed)
- Temperature -10° C to +70° C

**Mounting Information**

- See diagram at right for mounting information.

MARINE DATA RESERVES THE RIGHT TO MAKE CHANGES TO ITS PRODUCTS AND SPECIFICATIONS WITHOUT NOTICE